

| ITEM | QTY. | DESCRIPTION                 | LENGTH | REMARKS      |
|------|------|-----------------------------|--------|--------------|
| 1    | 2    | 2x4x8' SPF LUMBER           | .      | -            |
| 2    | 1    | 2x3x8' SPF LUMBER           | .      | -            |
| 3    | 1    | 4'x8'x1/2" PLYWOOD          | .      | -            |
| 4    | 8    | 1 1/2" SCHEDULE 40 PVC PIPE | AR     | 48" FM FLOOR |
| 5    | 3    | CASTER, TCH 3.5"            | .      | -            |
| 6    | 6    | 1x1x1/8" STEEL ANGLE        | 24"    | -            |
| 7    | -    | 2 1/2" DECK SCREWS          | .      | 2 LBS.       |
| 8    | -    | 1 1/4" DECK SCREWS          | .      | 1 LBS.       |

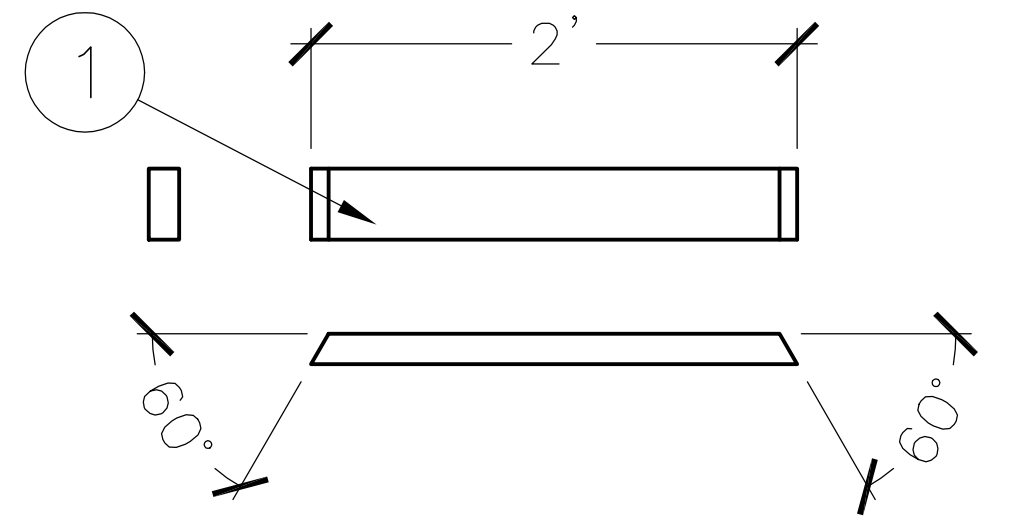

OUTER FRAME CUTS

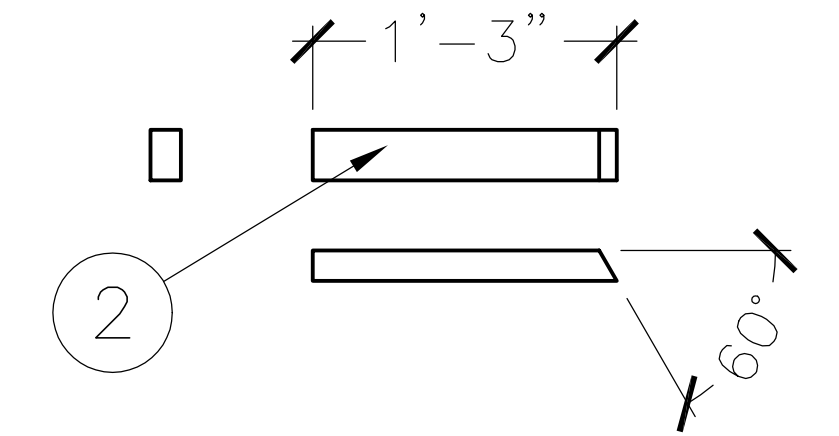

INNER FRAME CUTS

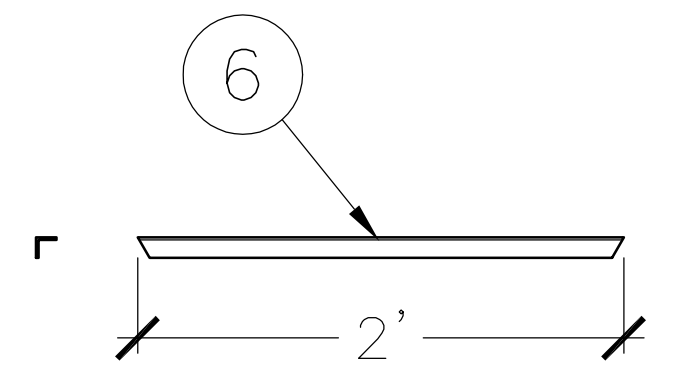

STEEL EDGING

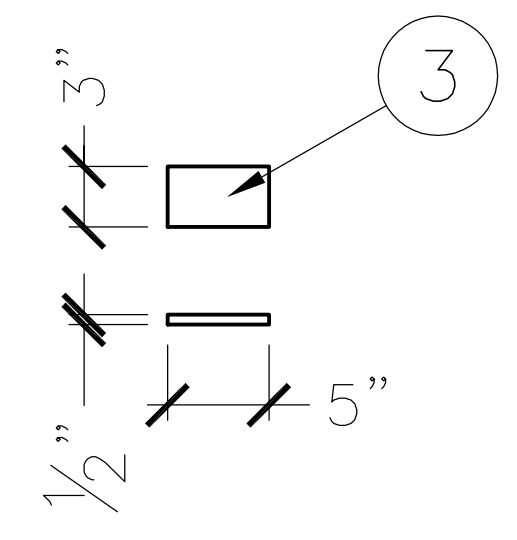

PIPE STOP

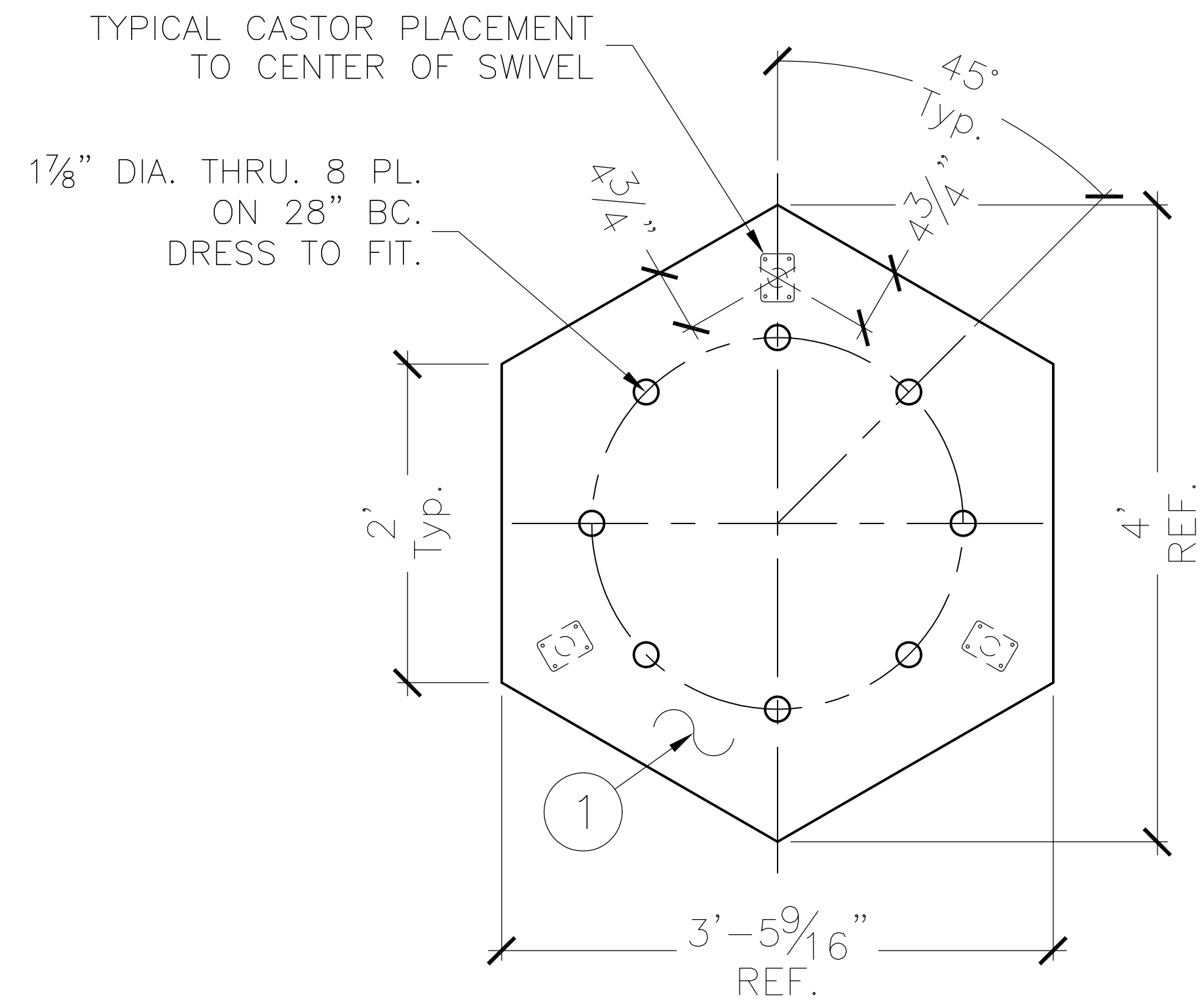
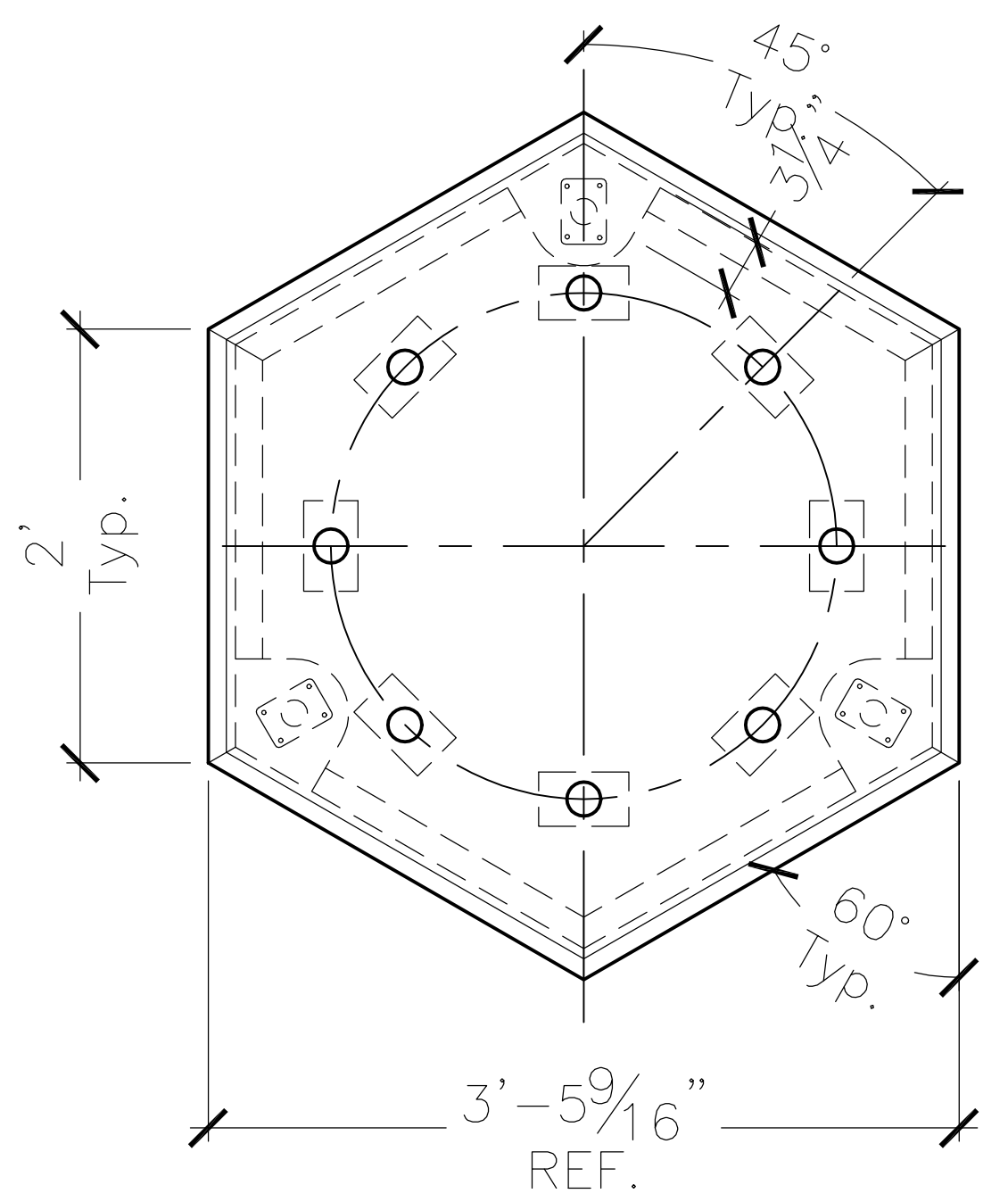

TOP DECK

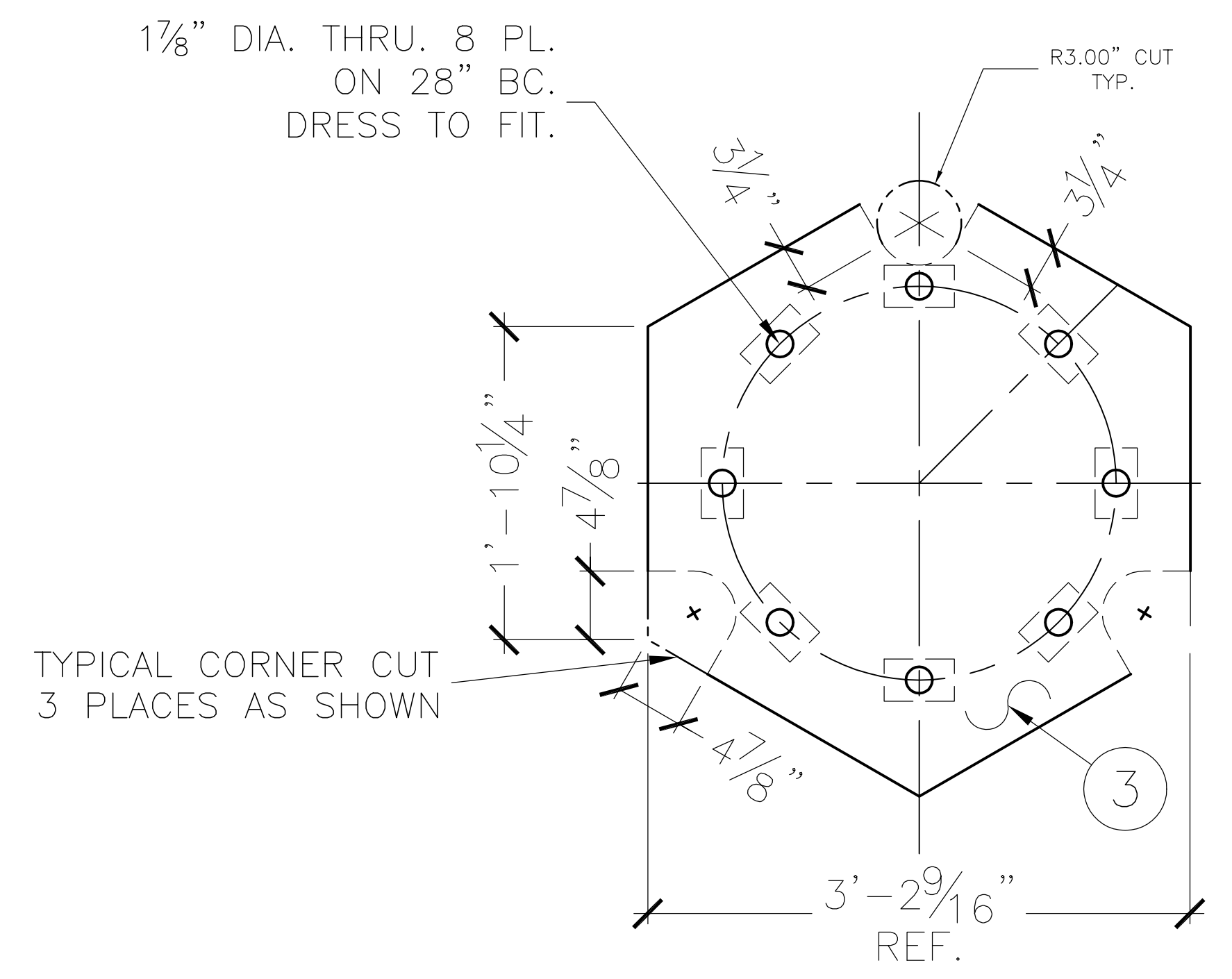

LOWER DECK

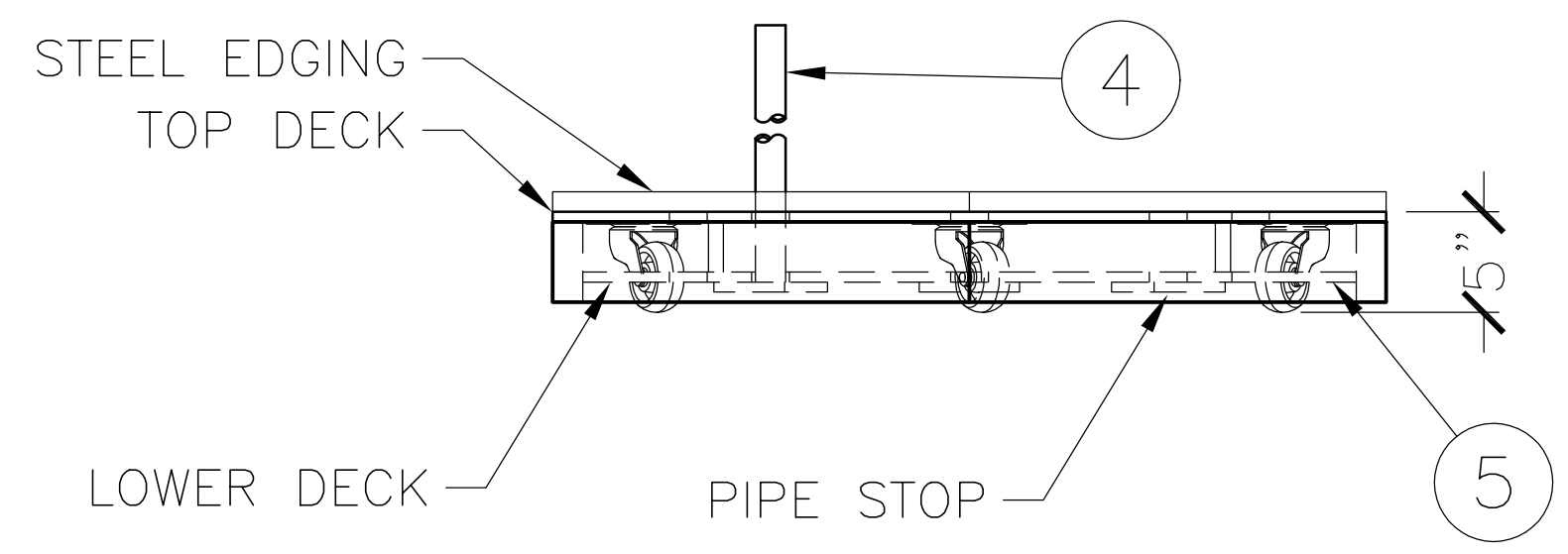

**FIRST**  
200 Bedford Street, Manchester, N.H. 03101  
(603) 666-3906 • FAX (603) 666-3907

|          |          |  |             |      |
|----------|----------|--|-------------|------|
| ENGINEER | DATE     | TITLE  |             |      |
| DRAWN    | DATE     | <b>2004 FIELD ELEMENTS<br/>MOVEABLE GOAL</b> |             |      |
| JRR      | 12/18/03 |  |             |      |
| CHECKED  | DATE     |  |             |      |
| APPROVED | DATE     | SIZE CLASS ID.                               | DRAWING NO. | REV. |
| ISSUED   | DATE     | D FAS  |             | -    |
|          |          | SCALE NA                                     |             |      |

SHEET 1 of 1